

**MATERIAL  
REQUIREMENTS  
PLANNING  
MRP**

*Report produced for the EC funded project*

*INNOREGIO: dissemination of innovation and knowledge management techniques*

by **Dr Vassilis Moustakis**  
Ass. Prof., Director Management Systems Lab  
D. of Production and Management Engineering  
Technical University of Crete

J A N U A R Y 2 0 0 0

## Contents

1	Description.....	2
1.1	What is the Material Requirements Planning IMT .....	2
1.2	MRP objectives .....	3
1.3	Methodology of a MRP project implementation / alternative techniques .....	4
1.4	Generic model for implementing MRP .....	5
1.5	Organizational measures for effective MRP implementation .....	5
1.6	Classes of MRP user/companies .....	6
2	Application .....	13
2.1	Where the technique has being applied.....	13
2.2	Types of firms / organizations that MRP can be applied .....	13
2.3	Duration and implementation cost of MRP .....	14
2.4	Conditions for implementation .....	15
2.5	Organizations Supporting the Implementation of MRP .....	15
3	Implementation Procedure of MRP .....	15
3.1	Steps / Phases of a MRP project .....	15
3.2	Partial techniques and tools included in each step .....	17
3.3	Related Software .....	17
4	Bibliographic references .....	19
5	Annex.....	20
	ANNEX A: Example MRP Application .....	20
5.1	Forecasting demand.....	20
5.2	Master Production Schedule.....	21
5.3	Bill of Materials (Product Structure) File.....	21
5.4	Inventory Records (Item Master) File .....	22
5.5	Running the MRP Program .....	22
5.6	Obtainability Control.....	25

# 1 DESCRIPTION

Material Requirements Planning is a time phased priority-planning technique that calculates material requirements and schedules supply to meet demand across all products and parts in one or more plants.

Information Technology plays a major role in designing and implementing Material Requirements Planning systems and processes as it provides information about manufacturing needs (linked with customer demand) as well as information about inventory levels. MRP techniques focus on optimizing inventory. MRP techniques are used to explode bills of material, to calculate net material requirements and plan future production.

This report focuses on MRP. However, it also discusses, where appropriate, MRPII systems. MRPII stands for Manufacturing Resource Planning and represents an extension of MRP. MRPII points to computer based planning and scheduling designed to improve management's control of manufacturing and its support functions. MRPII maps an extension of MRP to capture all manufacturing requirements including materials, human resources, scheduling, etc.

## 1.1 What is Material Requirements Planning

The globalization of the economy and the liberalization of the trade markets have formulated new conditions in the market place which are characterized by instability and intensive competition in the business environment. Competition is continuously increasing with respect to price, quality and selection, service and promptness of delivery. Removal of barriers, international cooperation, technological innovations cause competition to intensify. In terms of manufacturing emphasis is placed on reducing cost while improving quality. In addition, other factors such as timely delivery of the product become critical (this is captured by emphasis in Just in Time or JIT in short) techniques.

A key question to a MRP process is the number of times a company replenishes (or turns around) inventory within a year. There are accounts of inventory annual turnover ratios of greater than 100, mainly reported by Japanese companies. One can readily realize that the a high inventory ratio is likely to be conducive to lowering production cost since less capital is tied up to unused inventory.

MRP systems use four pieces of information to determine what material should be ordered and when (see also Exhibit 1-1 and Exhibit 1-2):

- ✓ the master production schedule, which describes when each product is scheduled to be manufactured;
- ✓ bill of materials, which lists exactly the parts or materials required to make each product;
- ✓ production cycle times and material needs at each stage of the production cycle time; and,
- ✓ supplier lead times.

The master schedule and bill of materials indicate what materials should be ordered; the master schedule, production cycle times and supplier lead times then jointly determine when orders should be placed.

The Master Production Schedule includes quantities of products to be produced at a given time period. Quantities are included both at aggregate and detailed levels. Aggregate may refer to monthly production and detailed may refer to weekly or daily production. The master production schedule takes the form of a table in which rows represent products and columns represent time components. Entries of the table map to units of each product to be produced at a given time period.

Bill of Materials gives information about the product structure, i.e., parts and raw material units necessary to manufacture one unit of the product of interest. An illustration of a bill of materials to produce a desk lamp is given in Exhibit 1-3.

MRP was pioneered in the 1970's with the work of Orlicky. Later evolved or became part of integrated to Manufacturing Resource Planning systems (or MRPII). MRPII is a computer based planning and scheduling system designed to improve management's control of manufacturing and its support functions.

In today's corporate environment MRPII is often termed as ERP (or Enterprise Resource Planning). MRPII represents a group of software programs designed to tie together disparate company functions to create more efficient operations in areas such as assembly or delivery of products or services.

Thus MRP has evolved to become a component of a MRPII system. Technically, MRPII extends MRP and links it with the company's information resources such as human resource information system, financial management, accounting, sales, etc.

Such extension is typical according to modern trends in business management and modeling and made possible by advances in information technology. On the other hand, the need to integrate is well established in management thinking and practice. Since the pioneering work of Anthony during the sixties, management decision-making processes are viewed from extending from strategic planning, to management control and to operational control. MRP systems lay in-between management control and operational control processes. However, as detailed production data are linked with overall organizational information resources it becomes clear that MRP and MRPII system implementations play a significant role in company's corporate advantage.

## 1.2 MRP objectives

The main theme of MRP is "getting the right materials to the right place at the right time".

Specific organizational objectives often associated with MRP design and implementation may be identified among three main dimensions, namely: inventory, priorities and capacity:

<b>Dimension:</b>	<b>Objective specifics</b>
Inventory:	<ul style="list-style-type: none"> <li>- Order the right part</li> <li>- Order the right quantity</li> <li>- Order at the right time</li> </ul>
Priorities:	<ul style="list-style-type: none"> <li>- Order with the right due date</li> <li>- Keep the due date valid</li> </ul>
Capacity:	<ul style="list-style-type: none"> <li>- Plan for a complete load</li> <li>- Plan for an accurate load</li> <li>- Plan for an adequate time to view future load</li> </ul>

Objectives of MRP should be identified with regard to inputs and outputs associated with it. Inputs are delineated with master production schedule, bill of materials, etc. (see Exhibits 1-1 and 1-3).

Therefore, a clear specification of MRP objectives should be associated with a respectively clear description of objectives of MRP inputs as well as MRP outputs.

### **1.3 Methodology of a MRP project implementation / alternative techniques**

MRP represents an innovation in the manufacturing environment. Thus, its effective implementation requires explicit management action. Steps need to be clearly identified and necessary measures be taken to ensure organizational responsiveness to the technique being implemented.

“Cookbook” like models for implementing MRP does not exist. Each organization poses a unique environment and that means that specific actions need to be taken with due regard to environment specifics.

We approach MRP as an organizational innovation and identify the necessary measure which management should adopt in implementing it. Motivational influences underlying MRP implementation include:

1. *Recognition of business opportunity* for the timely acquisition of MRP.
2. *Recognition of technical opportunity* for the timely acquisition of the technologies supporting MRP implementation.
3. *Recognition of need* for solving manufacturing and/or inventory problems using MRP.

Given the above motivational factors one may readily identify *what* and *how* issues underlying MRP design and implementation.

*What* refers to a generic process model composed of steps and indicative levels of effort to implement each step.

*How* refers to management involvement with respect to the process.

#### 1.4 Generic model for implementing MRP

We set a time framework of 12 months for implementing MRP. (Time may be shorter assuming that component activities may be completed earlier). However, a time span of 12 months is robust and draws from experience in implementing MRP (or even MRPII) systems. In Exhibit 1-4, there is a detailed report about the duration that last each phase of the MRP implementation.

Cost is specified in terms of % of total effort and represents manpower (i.e., in person – months). Cost associated with capital acquisition (hardware or software) is not included. However, capital acquisition often represents less than 33% of the total cost. In addition, cost associated with MRP operation is not included (to this end often cost is absorbed by company overhead).

#### 1.5 Organizational measures for effective MRP implementation

Experience shows that failures in MRP system implementation draw from two factors, namely:

1. Lack of strategic choices needed to configure MRP system and processes; and,
2. Implementation, which spins out of business control.

Key to MRP success is organizational involvement. Successful implementations are, more often than not, linked with Chief Executive Officer (CEO) involvement in the process. CEO involvement sets the necessary conditions to concerted organizational action.

Another rule is to avoid system development based on ‘nice to have features’. Information provided by the MRP system should tune with level of detail required in manufacturing. A system may be impressive; however, incorporate unnecessary functionality. For example, when a manufacturing system using Japanese Kanban visual signals needs more raw materials from a supplier, production workers pull a card and send it to the supplier. It would therefore be a mistake to place a firewall and to separate current practice from MRP system implementation. This is the reason that ‘assessment of current situation’ (see process model) should be performed at the level indicated in the diagram (see Exhibit 1-4) to capture and model organizational specifics and to try to fit MRP around them.

Continuous monitoring of design and implementation activities drives successful MRP instances. To this end, an issue, which should not be overlooked, is *interfaces* with other organizational information resources. Indeed MRP is part of the organizational information management infrastructure and from that point of view it contributes to the achievement of broader goals associated with quality, customer satisfaction, just in time delivery, etc. On the other hand, monitoring requires *metrics*. Metrics need not be universal; instead they should correspond to production planning requirements with respect to both supply and production output.

In Exhibit 1-5, we link product characteristics with material attributes. In terms of products we distinguish between three types by focusing on demand profile and production setup cost. With respect to materials we distinguish between four types of material by focusing on pattern of usage in production (steady vs. varying use), degree of cooperation with supplier, demand and cost. Entries of the table may be used to specify performance metrics with due

regard to production specifics. Note that a single MRP system may be assessed using different metrics according to product manufacturing to which is targeted.

A different perspective about metrics is identified when MRP is placed in context with organizational resource planning – see Exhibit 1-6.

### **1.6 Classes of MRP user/companies**

MRP systems fall into four categories, often identified as ABCD, in terms of use and organizational implementation.

Class A represents full implementation of MRP. MRP system is tied up with company's financial system and includes capacity planning, shop floor dispatching, and vendor scheduling as well as links with human resource planning. There exists continuous monitoring of performance and inventory records and master production schedules are accurate.

Class B represents a less than full implementation. MRP system is confined in the manufacturing area; however, it encompasses master production scheduling.

Class C represents a classical MRP approach in which the system is confined to management of inventories.

Class D represents a data processing application of MRP. System is used for keeping track of data rather than as decision-making tool.

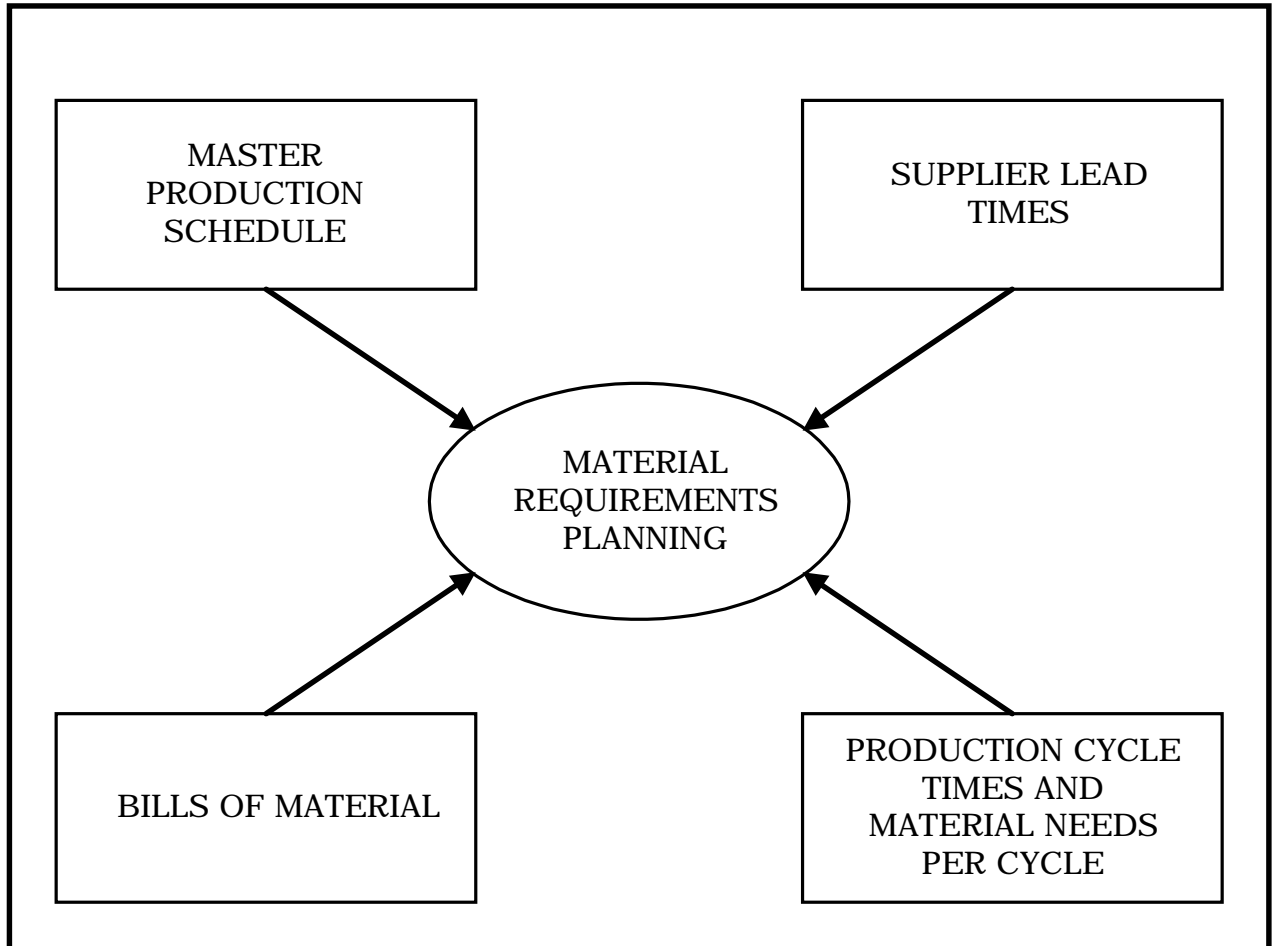
**Exhibit 1-1.** MRP in context with production management processes

In the schema presented we list the traditional components of MRP systems. A company using the above schema may be classified as a Class C MRP system user (see section 1.3: Methodology of MRP project implementation).

**Exhibit 1-2.** Overall View of the Inputs to a Standard Material Requirements Program and the Reports Generated by the Program

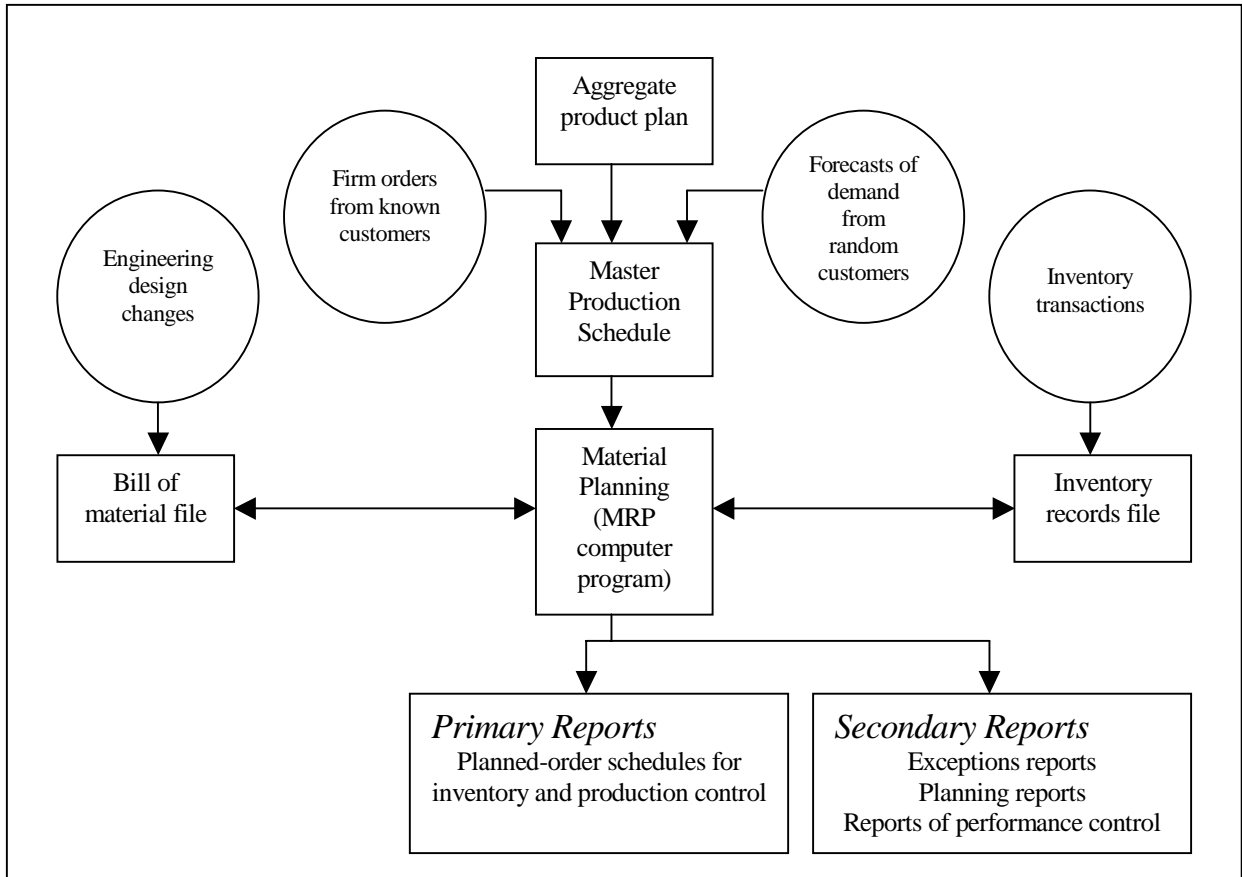

**Exhibit 1-3.** An indicative (partial) bill of materials (numbers represent no. of components).

The diagram presents a partial view of a BOM (Bill of Materials) view to produce a desk lamp.

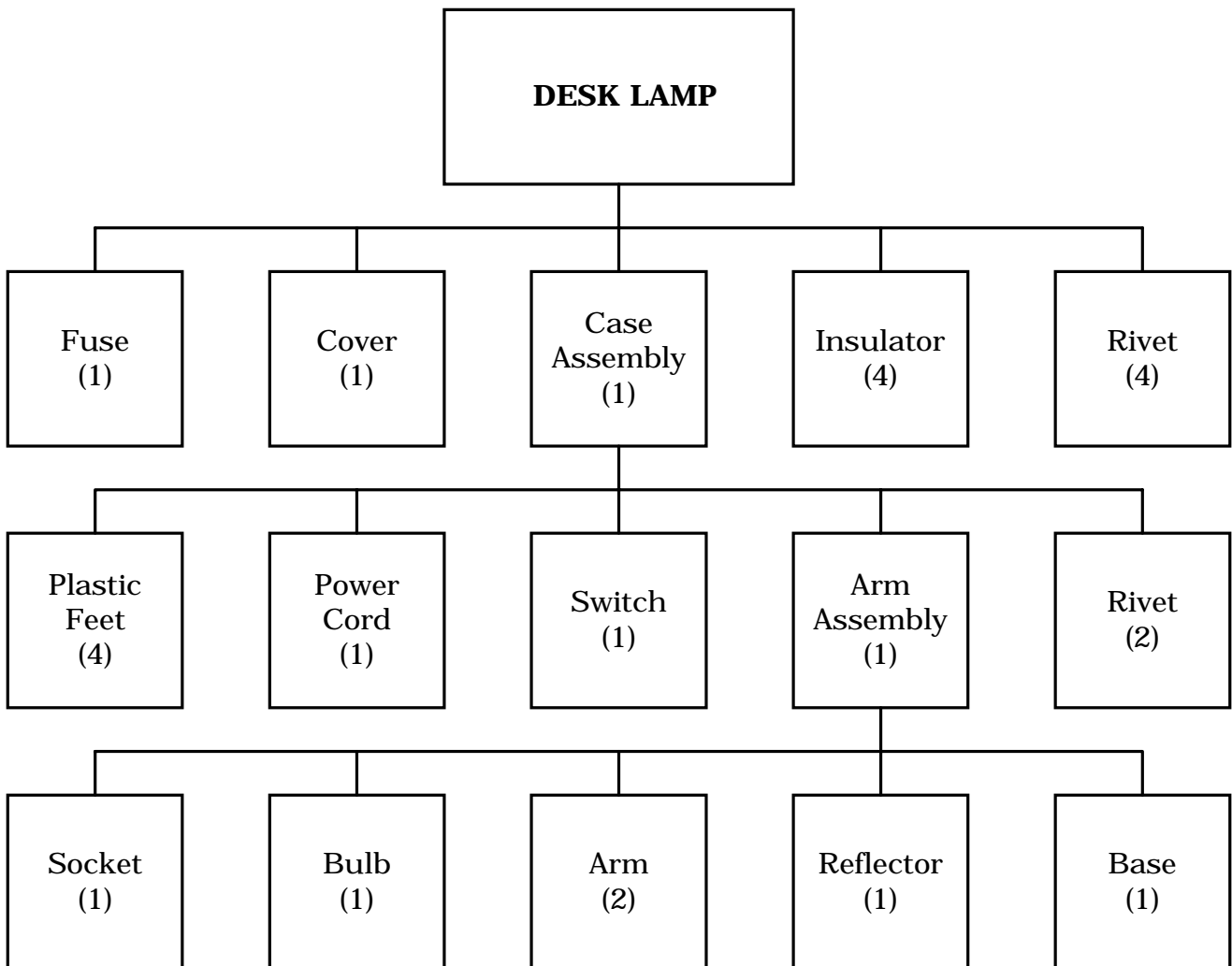

**Exhibit 1-4.** Process model for implementing MRP

Activity	Months												Brief activity description (% in parenthesis represent partition of the total manpower effort)	
	1	2	3	4	5	6	7	8	9	10	11	12		
Assessment of the present situation	■	■	■											Includes all activities associated with description and modeling of business practice with respect to inventory management, ordering of materials, and manufacturing planning. (20 %)
Production Scheduling			■	■	■	■								Formalization of production scheduling procedures. (15 %)
Design BOM				■	■	■								Design and implementation of the Bills of Materials into company's information system*. (15%)
Design of MRP/MRP II processes and system.						■	■	■	■					Includes the design of the MRP II system (often this may be based on adapting commercial software to company specifics). (30%)
Design of MRP/MRP II system interfaces							■	■	■	■				MRP should link with other organizational information resources (i.e., ERP system). (10%)
Test and evaluation								■	■	■	■	■		Assessment of system before it is introduced in the workplace. Often this activity feeds back to Design. (10%)

\*If the company lacks information system implementation then generic model of implementation should be modified. Often in cases in which the company starts from zero MRP comes as part of an integrated information system platform (such as SAP) and implementation is associated with extensive reengineering of business processes.

MRP II implementation is broader and likely to incorporate components that are not confined to production planning and scheduling. However, tasks listed above are present in MRP II implementation; effort may increase but percentages may not change.

**Exhibit 1-5.** Tool for defining MRP performance metrics.

Material attributes	Product characteristics		
	Make to stock (high demand profile products)	Make to order (low demand profile products with high setup cost)	Assemble to order (low demand profile products with low setup cost)
Just-in-Time high demand high value steady consumption close cooperation with supplier short delivery	MRP system should exhibit <u>Just in Time</u> performance characteristics. Use cost and time measures.		
Reorder point high demand medium value varying consumption close cooperation with supplier short delivery			
MRP high demand medium value varying consumption long delivery			
EOQ* low value steady consumption			

\*Economic Order Quantity

The matrix presented herein may be used to define performance metrics for assessing MRP/MRP II like systems.

**Exhibit 1-6.** Manufacturing Resource Planning (MRPII)

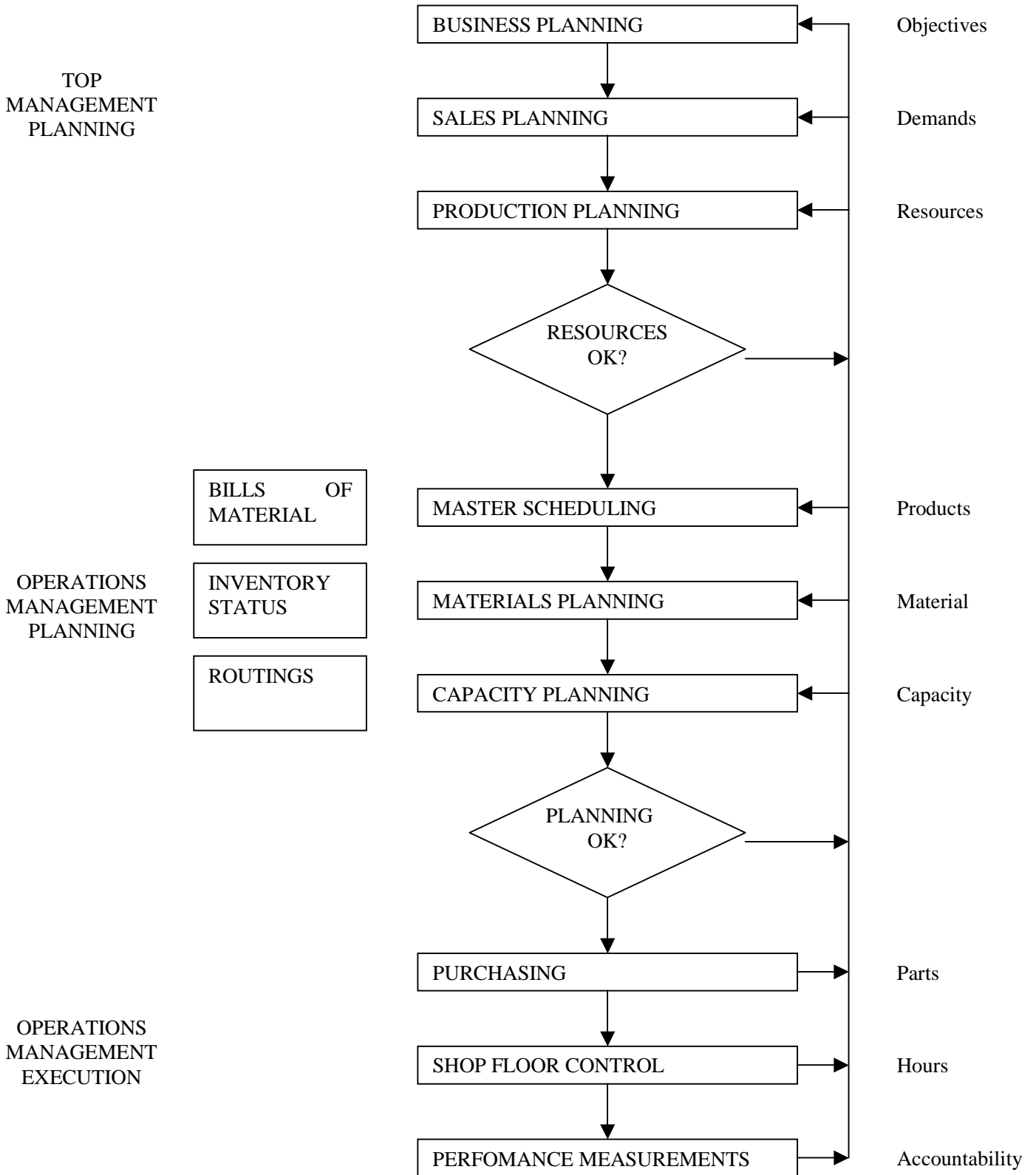

## 2 APPLICATION

### 2.1 Where the technique has been applied

MRP started in the late 1960s. The technique was applied first to mobile and airplane industry. As the technique became well known, many large and small businesses adopted MRP method in order to increase their productivity and decrease the production cost.

SATO was one of the many companies that recognized the need of MRP system. SATO is a dynamic business that deals with the design and the production of office furniture. Because of the increasing demands of the market during the last years and the competition, SATO, like many other companies, had to confront with the following challenges:

- ✓ good quality products
- ✓ competitive prices
- ✓ reduction of the deliver time
- ✓ great variety of products

SATO recognized that one of the most significant factors in order to face these challenges was the effective production management. The implementation of the MRP system had as result the increase of productivity and the reduction of the production cost.

In the paragraph that follows, there is a detailed report of what kinds of companies use MRP systems.

### 2.2 Types of firms / organizations that MRP can be applied

MRP is being used in a variety of industries with a job-shop environment (meaning that a number of products are made in batches using the same productive equipment). The list in Exhibit 2-1 includes process industries, but the processes mentioned are confined to job runs that alternate output product and do not include continuous process such as petroleum or steel. MRP is most valuable to companies involved in assembly operations and least valuable to those in fabrication.

**Exhibit 2-1.** Industry Applications and Expected Benefits of MRP

<b>Industry Type</b>	<b>Examples</b>	<b>Expected Benefits</b>
Assemble-to-stock	Combines multiple component parts into a finished product, which is then stocked in inventory to satisfy customer demand. Examples: watches, tools, appliances.	High
Fabricate-to-stock	Items are manufactured by machine rather than assembled from parts. These are standard stock items carried in anticipation of customer demand. Examples: piston rings, electrical switches.	Low
Assemble-to-order	A final assembly is made from standard options that the customer chooses. Examples: trucks, generators, motors.	High
Fabricate-to-order	Items manufactured by machine to customer order. These are generally industrial orders. Examples: bearings, gears, fasteners.	Low
Manufacture-to-order	Items fabricated or assembled completely to customer machine tools. Examples: turbine generators, heavy machine tools.	High
Process	Industries such as foundries, rubber and plastics, speciality paper, chemicals, paint, drug, food, processors.	Medium

MRP does not work well in companies in companies that produce a low number of units annually. Especially for companies producing complex expensive products requiring advanced research and design, experience has shown that lead times tend to be too long and too uncertain, and the product configuration too complex for MRP to handle. Such companies need the control features that network-scheduling techniques offer.

### 2.3 Duration and implementation cost of MRP

The duration of each step is explained in paragraph 1.4 with related references to the Exhibit 1-4. Cost drivers influencing MRP system development and implementation include:

*Driver 1:* the number of the end items that are produced:

*Driver 2:* the complexity of the production procedure of the end items.

*Driver 3:* the frequency of the orders for end items and components.

All the above cost drivers influence the development and the implementation of the MRP system, because they increase the complexity of the production procedure. MRP must be adjusted to the needs of the production procedure. If there are many variables that affect the production, the necessary time and the cost of the implementation increase.

Based on experience, the implementation of a MRP system usually costs 13000-130000

EURO.

#### 2.4 Conditions for implementation

Several requirements have to be met, in order to give an MRP implementation project a chance of success:

- ✓ Availability of a computer based manufacturing system is a must. Although it is possible to obtain material requirements plan manually, it would be impossible to keep it up to date because of the highly dynamic nature of manufacturing environments.
- ✓ A feasible master production schedule must be drawn up, or else the accumulated planned orders of components might “bump” into the resource restrictions and become infeasible.
- ✓ The bills of material should be accurate. It is essential to update them promptly to reflect any engineering changes brought to the product. If a component part is omitted from the bill of material it will never be ordered by the system.
- ✓ Inventory records should be a precise representation of reality, or else the netting process and the generation of planned orders become meaningless.
- ✓ Lead times for all inventory items should be known and given to the MRP system.
- ✓ Shop floor discipline is necessary to ensure that orders are processed in conformity with the established priorities. Otherwise, the lead times passed to MRP will not materialize.

#### 2.5 Organizations Supporting the Implementation of MRP

The importance and the need for Material Requirements Planning in the small and medium enterprises and to bigger companies as well, is great. There are organizations and consulting firms that support and promote the implementation of MRP.

MRP supporting organizations:

- **APICS** (American Production and Inventory Control Society) - *The Educational Society for Resource Management*. URL: <http://www.apics.org/>
- **SOLE** (The International Society of Logistics). URL: <http://www.sole.org>
- A variety of consulting firms such as:
- **The Copley Consulting Group**. URL: <http://www.copleycg.com>
- **BILD, LLC Company**. URL: <http://www.bild.com>
- **NJN Consulting**. URL: <http://www.talon.net/njn/>
- **Planning S. A. (Greece)**.

### 3 IMPLEMENTATION PROCEDURE OF MRP

#### 3.1 Steps / Phases of a MRP project

The material requirements planning portion of manufacturing activities interacts with the master schedule, bill of materials file, inventory records file, and the output reports. In this section, we specialize further the process model presented in Exhibit 1-4.

**INPUTS TO A STANDARD MRP PROGRAM**

**Demand for Products:** Product demand for end items stems from two main reasons. The first is known customers who have placed specific orders, such as those generated by sales personnel, or from interdepartment transactions. The second source is forecast demand. Demand from known customers and demand forecast are combined and become the input to the master production schedule.

**Bill of Materials File:** The bill of Materials file contains the complete product description, listing materials, parts, and components but also the sequence in which the product is created. The BOM file is often called the product structure file or product tree because it shows how a product is put together. It contains the information to identify each item and the quantity used per unit of the item of which it is a part.

**Inventory Records File:** Inventory records file under a computerized system can be quite lengthy. Each item in inventory is carried as a separate file and the range of details carried about an item is almost limitless. The MRP program accesses the status segment of the file according to specific time periods. These files are accessed as needed during the program run.

**MRP COMPUTER PROGRAM**

The MRP program works as follows:

- A list of end items needed by time periods is specified by the master production schedule.
- A description of the materials and parts needed to make each item is specified in the bill of materials file.
- The number of units of each item and material currently on hand and on order are contained in the inventory file.
- The MRP program “works” on the inventory file. In addition, it continuously refers to the bill of materials file to compute quantities of each item needed.
- The number of units of each item required is then corrected for on hand amounts, and the net requirement is “offset” to allow for the lead time needed to obtain the material.

**OUTPUT REPORTS**

*Primary Reports:* Primary reports are the main or normal reports used for the inventory and production control. These report consist of

1. *Planned orders* to be released at a future time.
2. *Order release notices* to execute the planned orders.
3. *Changes in due dates* of open orders due to rescheduling.
4. *Cancellations or suspensions* of open orders due to cancellation or suspension of orders on the master production schedule.
5. *Inventory status data.*

*Secondary Reports:* Additional reports, which are optional under the MRP system, fall into three main categories:

1. *Planning reports* to be used, for example, in forecasting inventory and specifying requirements over some future time horizon.
2. *Performance reports* for purposes of pointing out inactive items and determining the agreement between actual and programmed item lead times and between actual and

programmed quantity usage and costs.

3. *Exceptions reports* that point out serious discrepancies, such as errors, out of range situations, late or overdue orders, excessive scrap, or nonexistent parts.

### **3.2 Partial techniques and tools included in each step**

In order to achieve successful results from the use of a MRP system, many variables (e.g. demand of orders) must be taken into consideration and thorough examination. Statistical tools and forecasting techniques are necessary to predict the unknown demand. In addition to these, many more techniques are used, which are borrowed from the fields of:

- Production management
- Control of production
- Warehouse management

### **3.3 Related Software**

Since the start of MRP in the late 1960s, many systems have been developed and sold by many software and consulting firms. While other competing-type integrated information programs have been and will probably continue to be developed, MRP- based systems will likely stay in the lead. This is because the firms currently in MRP systems are continuing to develop and enhance them. In the Exhibit 3-1 that follows, there is a list of MRP software programs developed from various vendors. The list also includes MRPII and ERP software, which can be used in order to apply MRP method.

**Exhibit 2-2.** List of MRP Software

Product	Vendor	Description	http address
Monitor Manufacturing Software	<u>Monitor Systems of Toronto</u>	MRP	<a href="http://www.monitor-toronto.com">http://www.monitor-toronto.com</a>
Merlin MRP2000 for Windows	<u>Merlin</u>	MRP	<a href="http://www.merlinsys.co.uk">http://www.merlinsys.co.uk</a>
MRP	<u>INMASS</u>	MRP	<a href="http://www.inmass.com">http://www.inmass.com</a>
MRPlite:LS	<u>DbM</u>	MRP	<a href="http://www.erplite.com">http://www.erplite.com</a>
ERPlite DbM	<u>DbM</u>	MRP/ERP	<a href="http://www.erplite.com">http://www.erplite.com</a>
Manufacturing Spreadsheet Templates	<u>User Solutions Inc.</u>	Scheduling, MRP, and Miscellaneous templates for Lotus and Excel	<a href="http://www.usersol.com">http://www.usersol.com</a>
Resource Manager VBX	<u>Addsoft Coprporation</u>	Visual Basic Add-on for MRP	<a href="http://www.addsoft.com">http://www.addsoft.com</a>
MRP9000	<u>Intuitive Manufacturing Systems, Inc.</u>	MRP/Scheduling System	<a href="http://www.mrp9000.com">http://www.mrp9000.com</a>
Fourth Shift	<u>Fourth Shift, Inc.</u>	MRP/ERP	<a href="http://www.fs.com">http://www.fs.com</a>
Alliance/MFG	<u>Alliance Manufacturing Software</u>	MRP-II System	<a href="http://www.alliancemfg.com">http://www.alliancemfg.com</a>
Caliach MRP	<u>Caliach MRP</u>	MRP II System	<a href="http://www.caliach.com">http://www.caliach.com</a>
FINESSE ERP	<u>Enhanced Systems &amp; Services, Inc.</u>	ERP	<a href="http://www.essfinesse.com">http://www.essfinesse.com</a>
Impact Award	<u>Syspro, Inc.</u>	ERP/MRP II	<a href="http://www.sysprousa">http://www.sysprousa</a>
Macola Progression Series	<u>Macola Software</u>	ERP/MRP II	<a href="http://www.macola.com">http://www.macola.com</a>
Made2Manage	<u>Made2Manage, Inc.</u>	ERP/MRP II	<a href="http://www.made2manage.com">http://www.made2manage.com</a>
Manage2000	<u>ROI Systems Inc.</u>	ERP/MRP II	<a href="http://www.roisysinc.com">http://www.roisysinc.com</a>
MAX for Windows	<u>Micro-MRP</u>	MRP II	<a href="http://www.micromrp.com">http:// www.micromrp.com</a>
Micro-MAX	<u>Micro-MRP</u>	ERP/MRP II	<a href="http:// www.micromrp.com">http:// www.micromrp.com</a>
MISys	<u>Microcomputer Specialists</u>	MRP II	<a href="http:// lit.chilton.net/file/microcsp.htm">http:// lit.chilton.net/file/microcsp.htm</a>
pc/MRP	<u>Software Arts Consulting</u>	MRP II	<a href="http:// www.pcmrp.com">http:// www.pcmrp.com</a>
Priority	<u>Eshbel Technologies</u>	MRP II	<a href="http:// www.eshbel.com">http:// www.eshbel.com</a>
StockMaster	<u>Applied Micro Business Systems</u>	MRP II	<a href="http:// www.abms.com">http:// www.abms.com</a>
WebPlan	<u>Enterprise Planning Systems</u>	MRP II	<a href="http:// www.webplan.com">http:// www.webplan.com</a>

#### 4 BIBLIOGRAPHIC REFERENCES

1. Joseph Orlicky, **Materials Requirements Planning**, McGraw-Hill, 1975
2. Terry Lunn, et al, **Mrp: Integrating Material Requirements Planning and Modern Business (Business One Irwin/Apics Series in Production Management)**, Irwin Professional Pub, 1992
3. Carol A. Ptak, **Mrp and Beyond: A Toolbox for Integrating People and Systems**, Irwin Professional Pub, 1996
4. R/3 Simplification Group SAP Labs Inc., **MRP Strategies Made Easy 3.0D-3.1I**, Johnson Printing Service, 1998
5. Urban Wemmerlov, **Capacity Management Techniques for Manufacturing Companies With Mrp Systems**, Amer Production & Inventory Control Society, 1984
6. Dinesh Shenoy, Bikash Bhadury, **Maintenance Resources Management: Adapting Mrp**, Taylor & Francis, 1997
7. Vincent C. Guess, **Engineering: The Missing Link in Mrp**, ASIN, 1997
8. Smolik, **The Material Requirements of Manufacturing**, ASIN
9. Joseph Orlicky, **Material Requirements Planning: The New Way of Life in Production and Inventory Management**, ASIN
10. David A. Turbide, **MRP+; The Adaptation, Enhancement, and Application of MRP II**, Industrial Press Inc., 1993
11. John Kenworthy, **Planning and Control of Manufacturing Operations**, John Wiley & Sons, 1998
12. James H. Greene, American Production and Inventory Control society **Production and Inventory Control Handbook**, McGraw Hill, 1997
13. Thomas E. Vollmann, et al, **Manufacturing Planning and Control Systems**, Richard d Irwin, 1997
14. R. Thomas Wright, **Manufacturing Systems**, Goodheart-Willcox Co, 1990
15. John F. Proud, **Master Scheduling: A Practical Guide to Competitive Manufacturing**, John Wiley & Sons, 1995
16. Edward A. Silver, et al, **Inventory Management and Production Planning and Scheduling**, John Wiley & Sons, 1998
17. John W. Toomey, **Mrp II: Planning for Manufacturing Excellence (Chapman & Hall Materials Management/Logistics Series)**, Chapman & Hall, 1996
18. Oliver W. Wight, **Executives Guide to Successful Mrp II**, Oliver Wight Ltd Pub, 1994
19. Christopher D. Gray, et al, **Mrp II Standard System: A Handbook for Manufacturing Software Survival**, John Wiley & Sons, 1995
20. Jr. Donald H. Sheldon, Michael G. Tincher, **The Road to Class A Manufacturing Resource Planning (MRP II)**, Buker, 1997
21. Andreas Drexl, Alf Kimms, **Beyond Manufacturing Resource Planning (Mrp II): Advanced Models and Methods for Production Planning**, Springer Verlag, 1998
22. John N. Petroff, **Handbook of MRP II/JIT Integration and Implementation**, Prentice Hall, 1993

## Annex: Example MRP Application

ABC produces a line of electric meters installed in residential buildings by electric utility companies to measure power consumption. Meters used on single-family homes are of two basic types for different voltage and amperage ranges. In addition to complete meters, some parts and subassemblies are sold separately for repair or for changeovers to a different voltage or power load. Being certain that application of MRP could contribute to improving company's cost performance, Mark Hicks, ABC's manager of manufacturing developed an exemplar study to identify/assess potential.

The exemplar study, presented briefly herein, presents the application of MRP in the production of the two meters A and B. The structure of the study is presented in the Exhibit 5-1.

**Exhibit 5-1.** Structure of the study

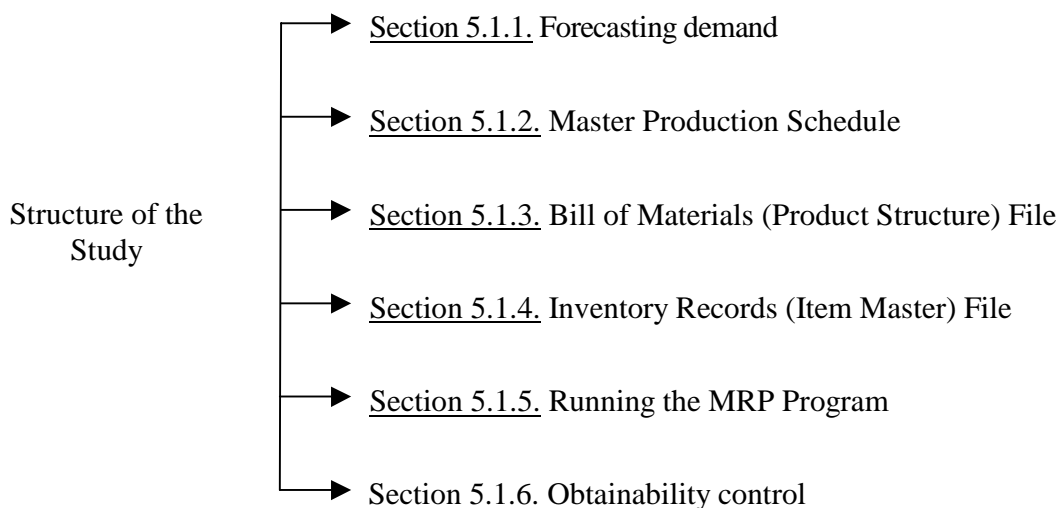

The problem for the MRP system is to determine a production schedule that would identify each item, the period it is needed, and the appropriate quantities. This schedule is then checked for feasibility, and the schedule is modified if necessary. The Exhibit 1-2 describes well the inputs required to run the MRP program.

### 5.1 Forecasting demand

Demand for the meters and components originate from two sources: regular customers that place firm orders, and unidentified customers that make the normal random demands for these items (Exhibit 5-2).

**Exhibit 5-2.** Future Requirements for Meters A and B, Subassembly D, and Part E Stemming from Specific Customer Orders and from Random Sources

	<b>Meter A</b>		<b>Meter B</b>		<b>Subassembly D</b>		<b>Part E</b>	
<i>Month</i>	<i>Known</i>	<i>Random</i>	<i>Known</i>	<i>Random</i>	<i>Known</i>	<i>Random</i>	<i>Known</i>	<i>Random</i>
3	1000	250	400	60	200	70	300	80
4	600	250	300	60	180	70	350	80
5	300	250	500	60	250	70	300	80
6	700	250	400	60	200	70	250	80
7	600	250	300	60	150	70	200	80
8	700	250	700	60	160	70	200	80

**5.2 Master Production Schedule**

Our schedule assumes that all items are to be available the first week of the month. Exhibit 5-3 shows the trial master schedule that we use, with demands for months 3 and 4 listed in the first week of the month, or as weeks 9 and 13.

**Exhibit 5-3.** A Master Schedule to Satisfy Demand Requirements as Specified in Exhibit 1-2

	<b>Week</b>									
	9	10	11	12	13	14	15	16	17	
<i>Meter A</i>	1250				850					550
<i>Meter B</i>	460				360					560
<i>Subassembly D</i>	270				250					320
<i>Part E</i>	380				430					380

**5.3 Bill of Materials (Product Structure) File**

The product structure for Meters A and B is shown in Exhibit 5-4 in the typical way using low level coding, in which each item is placed at the lowest level at which it appears in the structure hierarchy. Quantities in parentheses indicate the number of units required per unit of the parent item. Exhibit 5-5 shows an indented list for the structure of Meters A and B.

**Exhibit 5.4.** Product Structure for Meters A and B

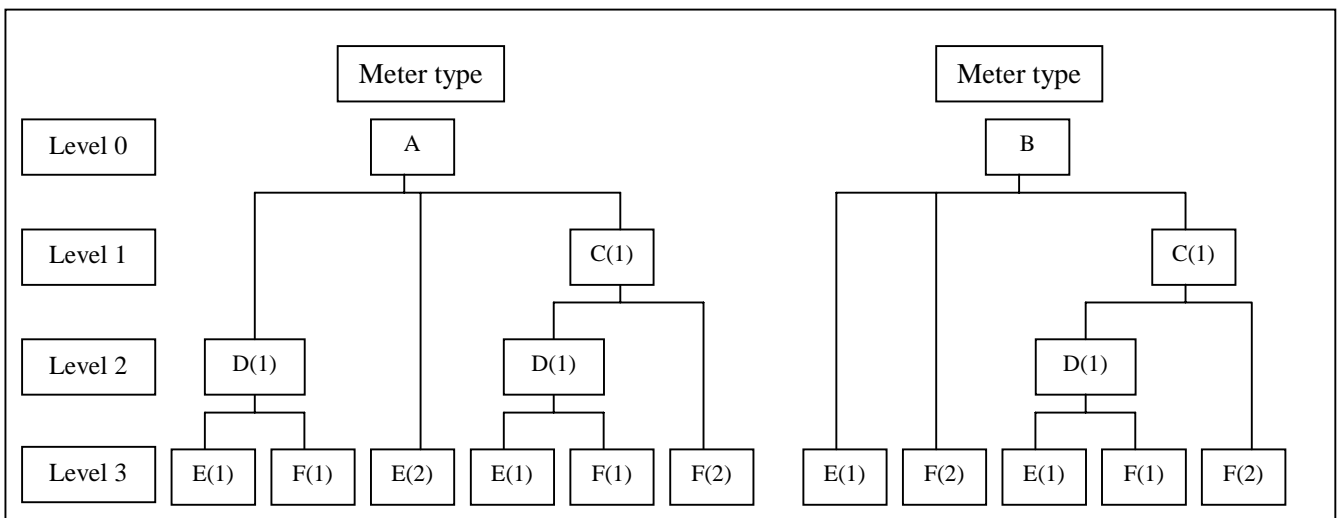

**Exhibit 5-5.** Indented Parts List for Meter A and B, with the Required Number of Items per Unit of Parent Listed in Parentheses.

<b>Meter A</b>		<b>Meter B</b>		
A		B		
	D(1)		E(1)	
			F(2)	
			C(1)	
	E(2)			D(1)
	C(1)			E(1)
		D(1)		F(1)
			E(1)	
			F(1)	
				F(2)
		F(2)		

**5.4 Inventory Records (Item Master) File**

For this example, the pertinent data contained in the inventory records file are the on-hand inventory at the start of the program run and the lead times. These data are shown in Exhibit 5-6.

**Exhibit 5-6.** Number of Units on Hand and Lead Time Data that Would Appear on the Inventory Record File

<b>Item</b>	<b>On-Hand Inventory</b>	<b>Lead Time (weeks)</b>
A	50	2
B	60	2
C	40	1
D	30	1
E	30	1
F	40	1

**5.5 Running the MRP Program**

The MRP program explodes the item requirements according to the BOM file, level by level, in conjunction with the inventory records file. A released data for the net requirements order is offset to an earlier time period to account for the lead-time. Orders for parts and subassemblies are added through the inventory file, bypassing the master production schedule, which, does not schedule at a low enough level to include spares and repair parts.

**Exhibit 5-7.** Material Requirements Planning Schedule for Meters A and B, Subassemblies C and D, and Parts E and F

Item		Week									
		4	5	6	7	8	9	10	11	12	13
<b>A</b>	Gross requirements						1250				850
	On hand 50						50				
	Net requirements						1200				
	(LT=2) Planned-order receipt						1200				
	← Planned-order release				1200						
<b>B</b>	Gross requirements						460				360
	On hand 60						60				
	Net requirements						400				
	(LT=2) Planned-order receipt						400				
	← Planned-order release				400						
<b>C</b>	Gross requirements				400						250
	On hand 40				1200						
	Net requirements				40						
	(LT=1) Planned-order receipt				1560						
	← Planned-order release			1560							
<b>D</b>	Gross requirements			1560	1200		270				430
	On hand 30			30	0		0				
	Net requirements			1530	1200		270				
	(LT=1) Planned-order receipt			1530	1200		270				
	Planned-order release		1530	1200		270					
<b>E</b>	Gross requirements		1530	1200	2400	270	380				
	On hand 30		30	0	0	0	0				
	Net requirements		1500	1200	2800	270	380				
	(LT=1) Planned-order receipt		1500	1200	2800	270	380				
	Planned-order release	1500	1200	2800	270	380					
<b>F</b>	Gross requirements		1530	3120	800	270					
	On hand 40		40	0	0	0					
	Net requirements		1490	4320	800	270					

(LT=1)	Planned-order receipt		1490	4320	800	270					
	Planned-order release	1490	4320	800	270						

Exhibit 5-7 shows the planned order release dates for this particular run. The following analysis explains the program logic. (We confine our analysis to the problem of meeting the gross requirements for 1250 units of Meter A, 460 units of Meter B, 270 units of Subassembly D, and 380 units of part E, all in Week 9)

*For the Meter A*

The 50 units of A on hand result in a net requirement of 1200 units of A (1250 units-50 units=1200 units). To receive Meter A in Week 9, the order must be placed in Week 7 to account for the two-week lead-time, as it is shown in the Exhibit 5-7.

*For the Meter B*

The same procedure follows for the item B resulting in a planned 400-unit order released in Week 7 (460 units-60 units=400 units)

The rationale for these steps, is that for an item to be released for processing, all its components must be available. The planned order release date for the parent item therefore becomes the same gross requirement period for the sub items.

*For the Subassembly C*

Referring to the Exhibit 3, level 1, one unit of C is required for each A and each B. Therefore, the gross requirements for C in Week 7 are 1600 units (1200 for A and 400 for B). Taking into account the 40 units on hand and the one-week lead-time, 1560 units of C must be ordered in Week 6.

*For the Subassembly D*

Referring to the Exhibit 3, level 2, one unit of D is required for each A and each C. The 1200 units of D required for A are gross requirements in Week 7, and the 1560 units of D required for C are the gross requirements for the Week 6. Using the on hand inventory first and the one week lead time results in the planned order releases for 1530 units in Week 5 and 1200 units in Week 6.

*For the item E*

Referring to the Exhibit 3, level 3, two units of E is required for each A. The 1200 units planned order release for A in Week 7 becomes the gross requirement for 2400 units of E in the same Week. One unit of E is used in each B, so the planned order release for 400 units of B in Week 7 becomes the gross requirement for 400 units of E in the same Week. Item E is also used in Item D at the rate of one per unit so, the 1530 units planned order release for D in Week 5 becomes the gross requirement for 1530 units of E in Week 5 and 1500-unit planned order release in Week 4 after accounting for the 30 units on hand and the one week lead time. The 1200-unit planned order release for D in Week 6 results in gross requirements for 1200 units of E in Week 6 and a planned order release for 1200 units in Week 5.

*For the item F*

Item F is used in B, C, and D. The planned order releases for B, C, and D become the gross

requirement for F for the same Week, except that the planned order release for 400 units of B and 1560 of C become gross requirement for 800 and 3200 units of F, since the usage rate is two per unit.

The independent order for 270 units of subassembly D in Week 9 is handled as an input to D's gross requirements for that Week. This is then exploded into the derived requirements for 270 units of E and F. The 380-unit requirement for Part E to meet an independent repair part demand is fed directly into the gross requirements for Part E.

### **5.6 Obtainability Control**

The bottom line of each item in Exhibit 5-7 is taken as a proposed load on the productive system. Mr. Hicks asked his colleagues to examine if the schedule was feasible, because if the schedule have been infeasible or the loading unacceptable, the master production schedule would have been revised and the MRP package was run again with the new master schedule. This was a simple example of MRP application. MRP implementation and execution have to confront many difficulties that are related to the complexity of the production system.